

OUTPUT SAMPLE -- Stamping

DELIVERY		TOTAL				DATE		REF.NO			
	1					PLANNED BY	CHECKED BY	APPROVED BY	PAGE 1 / 4		
MAKER	1			DIE DESIGN PLANNING SHEET							
PART NO 72381-51K00/10, 53K00/10				PART NAME PANER,FR COWL UPPER				DIE NAME (SYMBOL) DW		NO.OF DIES TO BE MADE 1	
PROCESS PLANNING						JPN SUPPLIER		MSC SUPPLIER		LINE NAME (MACHINE NAME)	PANEL CHECKER USE NO USE
OPE.NO	1/4	2/4	3/4	4/4		TOTAL	MATERIAL GRADE JAC270CC-45/45		PANEL WT Kg	RATIO	
SYMBOL	DW	TM/PC	RS/FL	PC/C-PC		4	APPROX.SHEET SIZE 1120X520X0.7		MATERIAL WT 3.2 Kg	%	
Common MACHINE							APPROX.DIE SIZE R/L:1750 F/B:1100 DH:760		DIE WEIGHT 4.5 ton		
PART SKETCH FOR OPERATION						DIE SKETCH					
(PANEL INCLINATION & DIRECTIONS FOR FEEDING)						(DIE STRUCTURE & FEEDING HEIGHT)					
 <p style="text-align: center;">FRONT OF PRESS</p> <p style="text-align: right;">PUNCH PROFILE</p>											
DDPS Sample: Die Design Planning Sheet											
PART	MATERIAL (材質)	SURFACE TREATMENT (表面処理・熱処理)				TARGET HARDNESS (狙い硬度)					
1.PUNCH	FCD550										
2.B/H	FCD550										
3.UPPER DIE	FCD550										
MATERIAL OF DIE											

OUTPUT SAMPLE -- Stamping

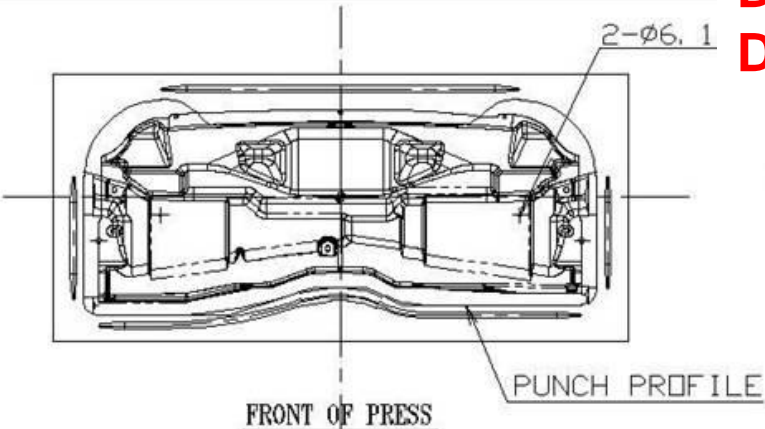
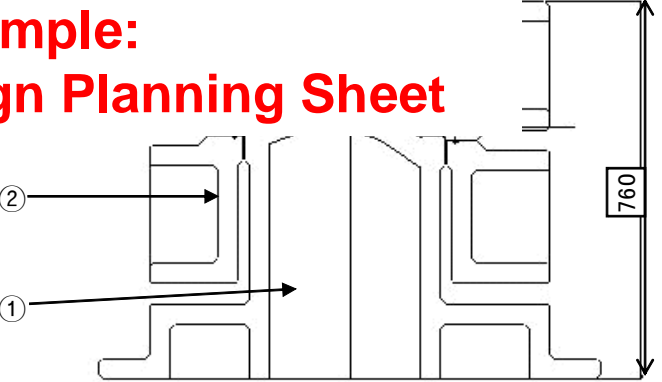
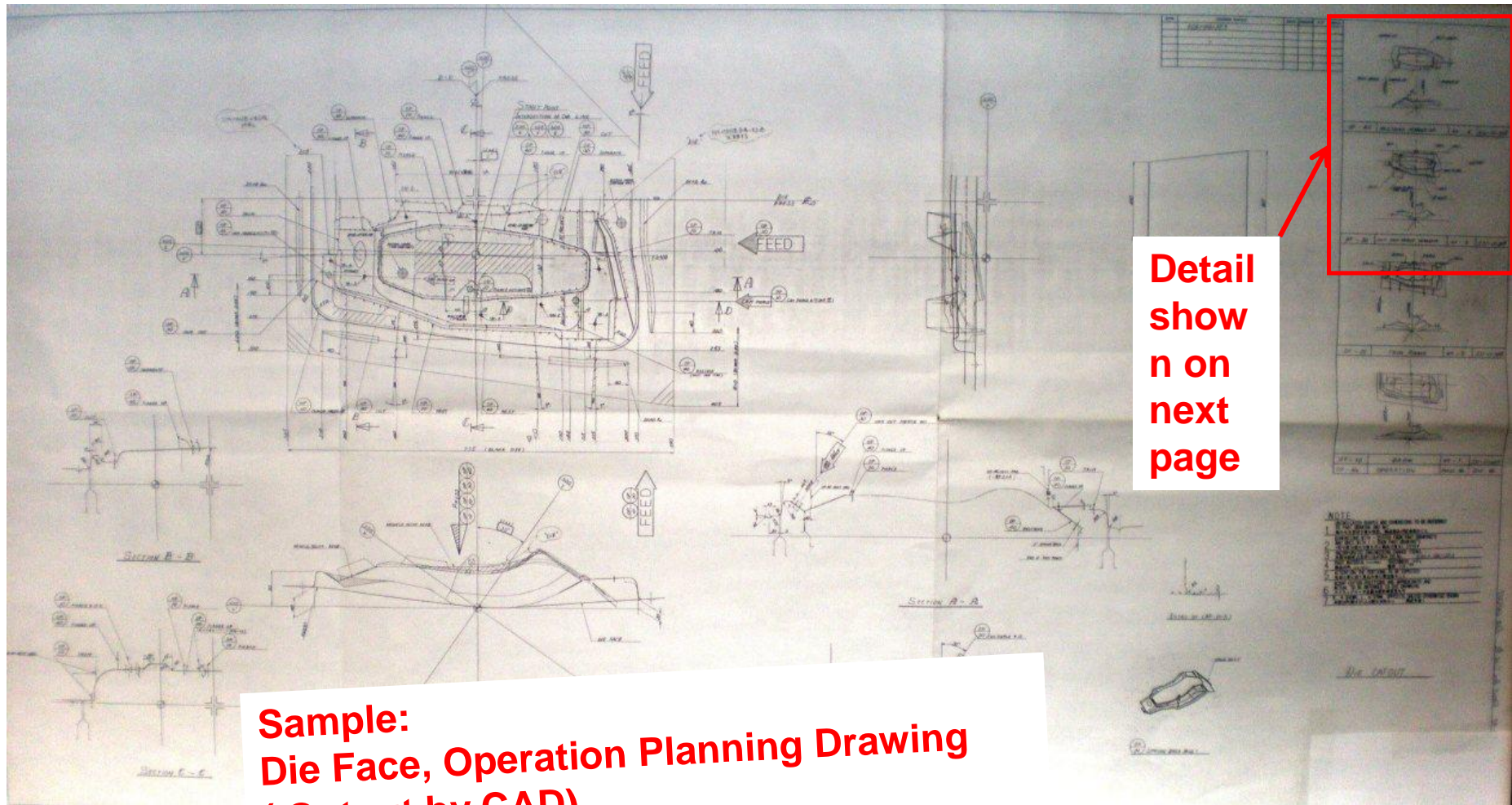

OUTPUT SAMPLE -- Stamping

Sample:
A detail of Die Face,
Operation Planning
Drawing (Output by
CAD)

